

Owner Handbook

Fireball COB Tri 90™

USE & MAINTENANCE

YOU MUST READ THESE WARNINGS carefully because they include important safety information about the installation, operation and maintenance of this product. Follow all instructions to maintain Manufacturer Warranty and for your own safety.

- Read all instructions in this User Manual and on the product carefully **BEFORE** operating this device.
- The latest version of this handbook can be found at www.lantalighting.com
- All Lanta products can be used for indoor use. Under no circumstances must these products be used outdoors unless stated otherwise.
- To prevent risk of fire or shock, do not expose products to rain or moisture.
- Make sure there are no flammable materials close to the unit during operation.
- Clean the product with a clean and dry, non-abrasive cloth. Do not use solvents or liquids to clean the product.
- There are no user replacement parts inside the product. Do not open the product for any reason. This will invalidate your Manufacturer Warranty and may impair the safety features of the product.
- Do not use if the product if you suspect it has been damaged in any way, including being dropped, is malfunctioning, or has been exposed to liquids or moisture. The unit must be repaired by an authorised service centre only. Manufacturer Warranty is void if unit is opened or adapted in any way. Operator safety may be compromised if this product is not operated and maintained in accordance with the details contained in this Owner Handbook.
- This appliance must be earthed. Do not remove the earth connection in the plug or any other location - it is essential for user safety.
- Power connection to the product is via a UK 240 Volt AC three-pin mains plug. Do not remove or adapt this plug. If necessary, only replace the plug top fuse with one of the same type, size and value.
- Be aware that products are mains powered and may be capable of producing high voltages from its outputs and has mains voltages inside the cabinet.

MAINS WARNINGS

- Always make sure that the mains voltage you intend to use is within the operating range of the product.
- Always unplug product from the mains supply before moving, cleaning etc.
- Make sure you replace the fuse with another of the same type and rating.
- This product will be irrevocably damaged and the warranty invalidated if connected to a power pack or other dimmer.
- Make sure the mains cable is not crushed or damaged.
- Never disconnect the mains lead by pulling or tugging on the cable.
- This appliance must be earthed. Do not remove the earth connection in the plug or any other location - it is essential for user safety.
- Unplug the product from the mains during lightning storms or periods of mains fluctuations. If the product is going to be unused for long periods, unplug from the mains.

PHYSICAL WARNINGS

- Always secure the product to a fastening device using a safety chain.
- If the product appears to be malfunctioning or operating in an unexpected manner, stop using the unit immediately and contact your supplier.
- Never lift, move or carry the product by any other means other than the case as a whole or handle if provided.

LASER WARNINGS - WHERE APPLICABLE

- Lasers are hazardous devices. Permanent eye injury and blindness is possible if lasers are used incorrectly.
- Avoid direct eye contact with laser light.
- Never intentionally expose your eyes or others to direct laser light.
- This laser product can potentially cause instant eye injury or blindness if laser light directly strikes the eyes.

- It is illegal and dangerous to shine a laser into audience areas, where the audience or other personnel could get direct laser beams or bright reflections into their eyes.
- It is illegal to shine any laser at aircraft.
- Never leave this device running unattended.

NON INTERLOCKING HOUSING WARNINGS

- This unit contains hazardous voltages, moving parts and high power laser emitters.
- Do not open the laser housing to avoid potential exposure to unsafe levels of laser radiation.
- The laser power levels, accessible if the unit is opened, can cause instant blindness, skin burns, and fires.

LASER SAFETY NOTES - WHERE APPLICABLE

YOU MUST READ THIS LASER SAFETY INFORMATION

Laser light is many thousands of times more concentrated than light from any other kind of light source and as so it poses a real danger to the sight. This concentration of light can cause instant eye injuries, primarily by burning the light sensitive portion at the back of the eye called the retina. Even if you cannot feel "heat" from a laser beam, it can still potentially injure or blind you or your audience. Even very small amounts of laser light are potentially hazardous even at long distances.

Laser eye injuries can happen quicker than you can blink.

- Entertainment products split the laser beam into hundreds of smaller laser beams that are radiated out at high speed. There is a misconception that an individual laser beam is safe for eye exposure. This is not the case. This product produces high levels of laser power - classified as Class 3B - before it splits into multiple beams - defined as Class 3R levels. Many of the individual beams are potentially hazardous to the eyes and should never be directed into an audience at any time.
- Do not assume that because the laser light is moving, it is safe. It isn't, and because these beams are being moved by a mechanical device, it is possible for that device to stop moving and then direct the laser beam constantly at an individual. Since eye injuries can occur instantly, it is critical to prevent the possibility of any direct eye exposure.
- It is illegal to aim a Class 3R laser into an area where people could be exposed, even below people's eye level.
- Always install a laser effect to ensure that the entire laser light radiation is at least 3 meters above the floor on which people can stand. It is very important to test the laser before any public use.
- Do not use if any defect is detected such as if the product emits only one or two laser beams rather than the expected quantities as this could indicate damage to the product and could allow emission of higher laser levels above Class 3R.
- Do not point lasers at any reflective surfaces such as windows, mirrors and metal truss or other reflective fixtures as even laser reflections can be hazardous.
- The operation of a class 3R laser show is only allowed if the show is controlled by a skilled and well-trained operator, familiar with the data included in this manual.
- The law is updated from time to time and it is the users sole responsibility to understand the legal obligations and responsibilities in force at the time and location of use.

We recommend visiting the Government Health & Safety website <http://www.hse.gov.uk> or search for "**Controlling the radiation safety of display laser installations**" for further information.

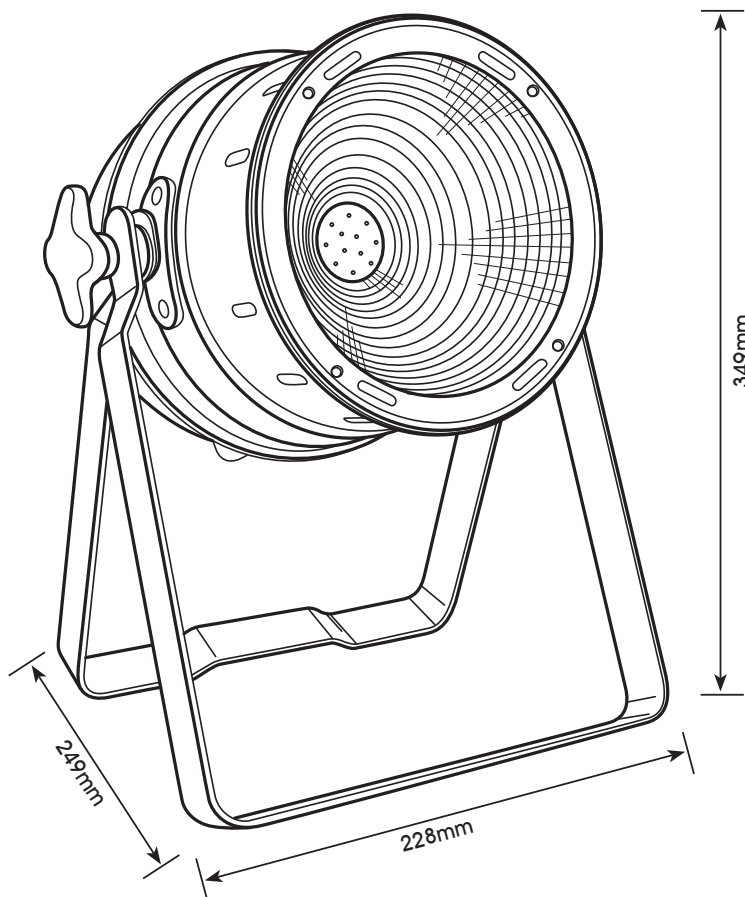

INTRODUCTION

Congratulations on your purchase of a Lanta Lighting Product. Based in the UK, Lanta are committed to providing high quality products at cost-effective prices to the professional lighting market. Since the first product was launched in 2006, Lanta has established a reputation for reliability, common sense design and customer support that has become the envy of others.

Other Lanta Lighting range include:

Professional Lighting:

From washes to floods, spots to projectors, LED technology now outperforms traditional lights while at the same time requiring significantly lower power and generating far less unwanted heat.

Performance Lasers:

Recent advances have reduced the costs of Lasers, made them more portable and brought improved performance and reliability. With step and animation lasers in multi and single colour formats for mobile DJs and static installs, Lanta promise Lasers that won't burn a hole in your pocket.

Atmospheric Effects:

When you need special atmospheric effects, Lanta have everything from bubble machines to fake snow, hazers and foggers. There's also a range of fluids and consumables specially designed to get the best from the range.

Control Gear:

Lightweight and portable, Lanta Control Gear is robust enough to survive life on the road and smart enough to control DMX kit whatever the venue.

Our website can be found at www.lantalighting.com and is available for the benefit of customers worldwide. Please consult for information, advice and support on this and other high quality products from Lanta

UNPACKING & INSPECTION

It is important that you carefully examine the packaging to ensure the product has not been damaged during shipping. If you are satisfied the packaging appears undamaged, carefully unpack the product. Please keep all of the packing materials in case you need to transport the device, pass it on to a new owner in the future or return it for some reason. Please examine the product and accessories to ensure they have arrived with you in good condition and show no sign of damage. If you suspect the product may be damaged, **DO NOT USE IT.** Please notify the sender immediately for advice – not the manufacturer.

INSIDE THE BOX

- 1 x Fireball COB Tri 90™
- IEC Power Cable

SPECIFICATIONS

Model Number	L24654
Light Source	90W COB (Chip on Board) Tri LED
Beam Angle	120°
Control	3, 6, 7 Channel DMX 512 control channels, LED display
Control Connections	3 Pin Female XLR, 3 Pin Male XLR IEC IN & OUT
Run Modes	Auto, DMX, Static Colour, Sound Active Built in Program, Master Slave
Construction	Die Cast Steel
Power Requirement	240V AC 50/60Hz
Power Consumption	90w
Dimensions (mm)	249 x 228 x 349
Weight (kg)	2.2

SAFETY INFORMATION

All information regarding important safety information about the installation, operation and maintenance of this product can be found at the back of this handbook. Products from Lanta Lighting meet all required safety standards in force at the time of manufacture and are fully compliant with them.

MANUFACTURER WARRANTY

- This Manufacturer Warranty is valid in the UK only.
- Lanta Lighting warrants that this product is free from workmanship defects and material failure during normal use and operation for a period of 12 months from first use or from original date of sale (whichever is the earliest) providing all of the terms indicated in the warranty section have been fully complied with.
- Expressly excluded is our liability for any directly connected or indirectly connected item or items or any consequential loss associated with the failure of the product howsoever caused.
- If the product has been opened, modified, tampered with, incorrectly connected, used inappropriately or in conflict with the instructions herein, or the product model or serial number has been damaged, removed, tampered with, obliterated or made partly unreadable by any person or persons, the Manufacturer Warranty is irrevocably null and void.
- No extension, adaption, alteration or modification to the terms of this Manufacturer Warranty will be permitted, unless expressly authorised in writing (excluding email and fax) by a Director of Lanta Lighting. Warranty is transferrable during the Warranty period.

OPERATING MODES

There are distinct operating modes that are supported by this unit. To select, use the "MODE" button to enter the menu. Holding the "MODE" button steps through specific settings for each operating mode and the "UP" and "DOWN" buttons chooses from the values available.

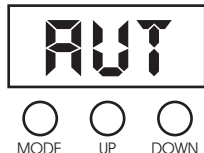

AUTO RUN MODE

AUT

Press the "MODE" button until the display shows "AUT". The fixture will cycle through the in-built programs.

IN BUILT PROGRAMS

PXX

In this sub-mode a built-in program can be chosen. With the LED Display reading "Pr01", Use the "UP" and "DOWN" buttons step between "Pr01" & "Pr7".

SPEED & STROBE

SXX **FXX**

There are additional functions available to the user within the Built in Hold the "MODE" button the display will show "SXX". By pressing the up and down buttons you can adjust the speed of the program. By pressing the "MODE" button for a second time the display will show "FXX". By pressing the up and down buttons you can adjust the strobe frequency of the program.

SLAVE MODE

SLA

Press the "MODE" until the display shows "SLA" to enter into Slave mode.

SOUND ACTIVE MODE

SUN

Press the "MODE" until the display shows "SUN" to enter into Sound mode. Hold the "MODE" button the display will show "SXX". By pressing the "UP" and "DOWN" buttons you can adjust the sound active sensitivity from "SU01" to "SU31".

STATIC COLOUR MODE

COL

Press the "MODE" until the display shows "COL" to enter into Static Colour mode. Hold the "MODE" button the display will cycle through the colours. By pressing "UP" and "DOWN" buttons you can adjust each colour intensity from "000" to "FL". When display shows "FXX". By pressing the up and down buttons you can adjust the strobe frequency of the program.

RESTORE FACTORY SETTINGS

SET

Press the "MODE" until the display shows "SeT" to enter into settings menu. Hold the "MODE" button, when the LED display show "rSt", press the "UP" at this time, will restore factory settings.

DMX MODE

d001

Press the "MODE" button until the display shows "d.001". Hold the "MODE" button, Press the "UP" and "DOWN" buttons to set the individual DMX value between d.001 - d.512. To select the number of channels, Hold the "MODE" button again, then the "UP" and "DOWN" buttons to cycle through the number of DMX channels you require.

LED Display Shows	DMX Control Mode
3-CH	3 CHANNEL
6-CH	6 CHANNEL
7-CH	7 CHANNEL

3CH

CHANNEL	VALUE	FUNCTION
CH1	0-255	RED
CH2	0-255	GREEN
CH3	0-255	BLUE

6CH

CHANNEL	VALUE	FUNCTION
CH1	0-255	DIMMER
CH2	0-255	RED
CH3	0-255	GREEN
CH4	0-255	BLUE
CH5	0-10	NO FUNCTION
	11-255	SOUND ACTIVE
CH6	0-255	STROBE

7CH

CHANNEL	VALUE	FUNCTION
CH1	0 - 255	DIMMER
CH2	0 - 255	RED
CH3	0 - 255	GREEN
CH4	0 - 255	BLUE
CH5	0-24	NO FUNCTION
	25-49	Pr.01
	50-74	Pr.02
	75-99	Pr.03
	100-124	Pr.04
	125-149	Pr.05
	150-174	Pr.06
175-199	Pr.07	
	200-255	SOUND ACTIVE
CH6	0 - 255	SPEED
CH7	0 - 255	STROBE

Lanta lighting is very focussed on saving the planet. Our products are low energy and our packaging is reduced to the minimum possible. We include our handbooks and specification sheets as part of our paper reduction programme. All our product handbooks and spec sheets are available on-line.

In this way you always get the latest version, available on any internet enabled device, at any time of the day or night, anywhere on the planet!



www.lantalighting.com